

HD514MR-7



DIGGING DEPTH

18'2"

OUTPUT RATING

105 HP

OPERATING WEIGHT

31,085 LBS

KATO

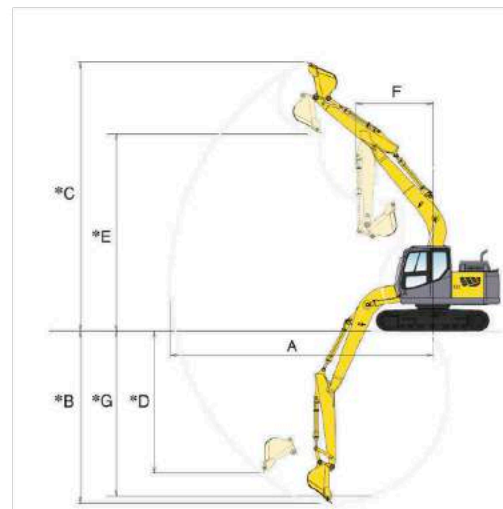
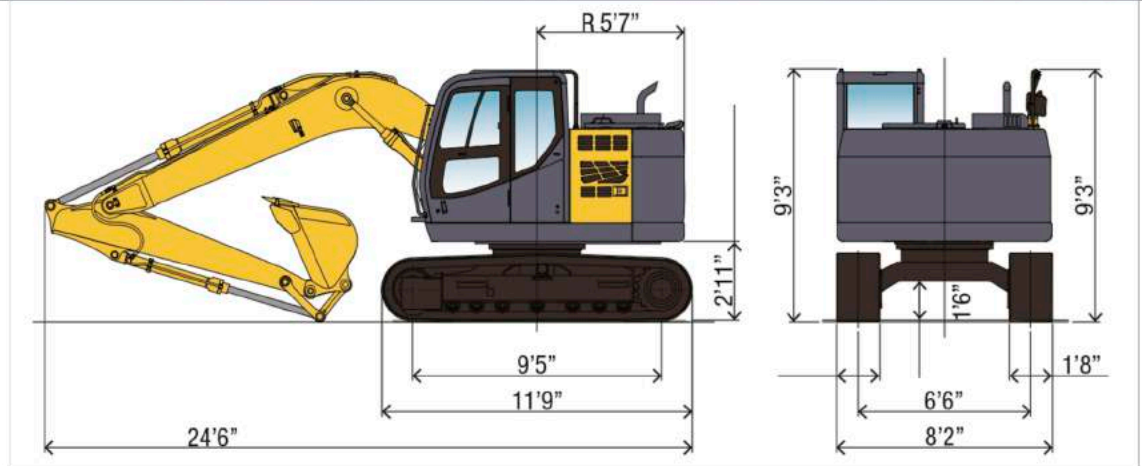

	514	Working Ranges	
		STD	Long Arm
A.	Max Digging Radius	27'9"	29'3"
B.	Max Digging Depth	18'2"	19'10"
C.	Max Digging Height	29'8"	30'9"
D.	Max Vertical Wall	15'	16'5"
E.	Max Dumping Height	21'11"	23'1"
F.	Max Swing Radius	7'11"	9'1"
G.	Max Digging Depth at 8' floor length	17'6"	19'2"



HD 514

MODEL	HD514
ENGINE	
Rated output	105 hp
Starter/Alternator	24 Volt
Max torque	277 lbf-ft/1800 rpm
Pumps	Double variable piston pump and gear pump
System flow	2 x 33.3 g/min
Max system psi	4554 psi
Max digging psi	4771 psi
Swing Speed	
Max swing speed	13.0/min
Travel speed high/low	3.6/2.1 mph
Gradeability	35°
Max drawbar pull	24,504 lbs
Digging Force	
Arm digging force *at high power	15,511 lbs 16,186 lbs
Bucket digging force * at high power	21,132 lbs 22,031 lbs
Service Data	
Fuel tank	73 gal
Cooling system	5.5 gal
Engine oil	5.17 gal
DEF tank capacity	14.5 gal
Hydraulic oil tank	41.7 gal
Operating weight	31,085 lbs
Ground Pressure	6.38 psi

KATO

EXCAVATORS AND TRACK LOADERS

www.isequipmentkc.com

16400 East Kentucky Rd.
Independence, Mo 64058
(816) 429-1600